

# Wiring of power box

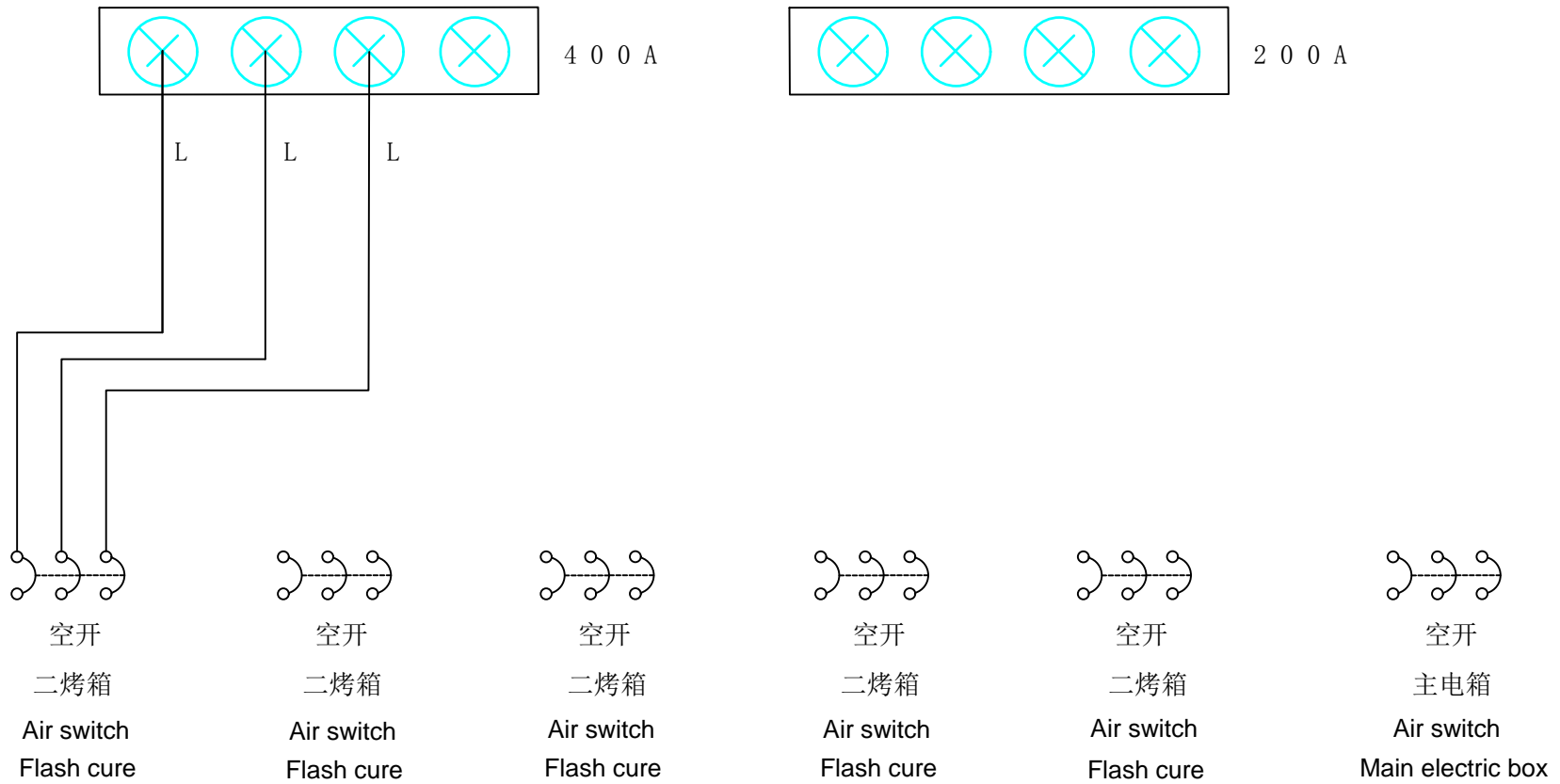

电气图纸名:	进电箱	版本	X0.1
图号:	ST-RX-JL-01	数量	比例
制作:	广州市碧宏印刷科技有限公司		
共 9 页	第 1 页	Guangzhou bihong	

图纸编号 ST

### Wiring of main and sub power box

Alternating voltage  
交流 220V

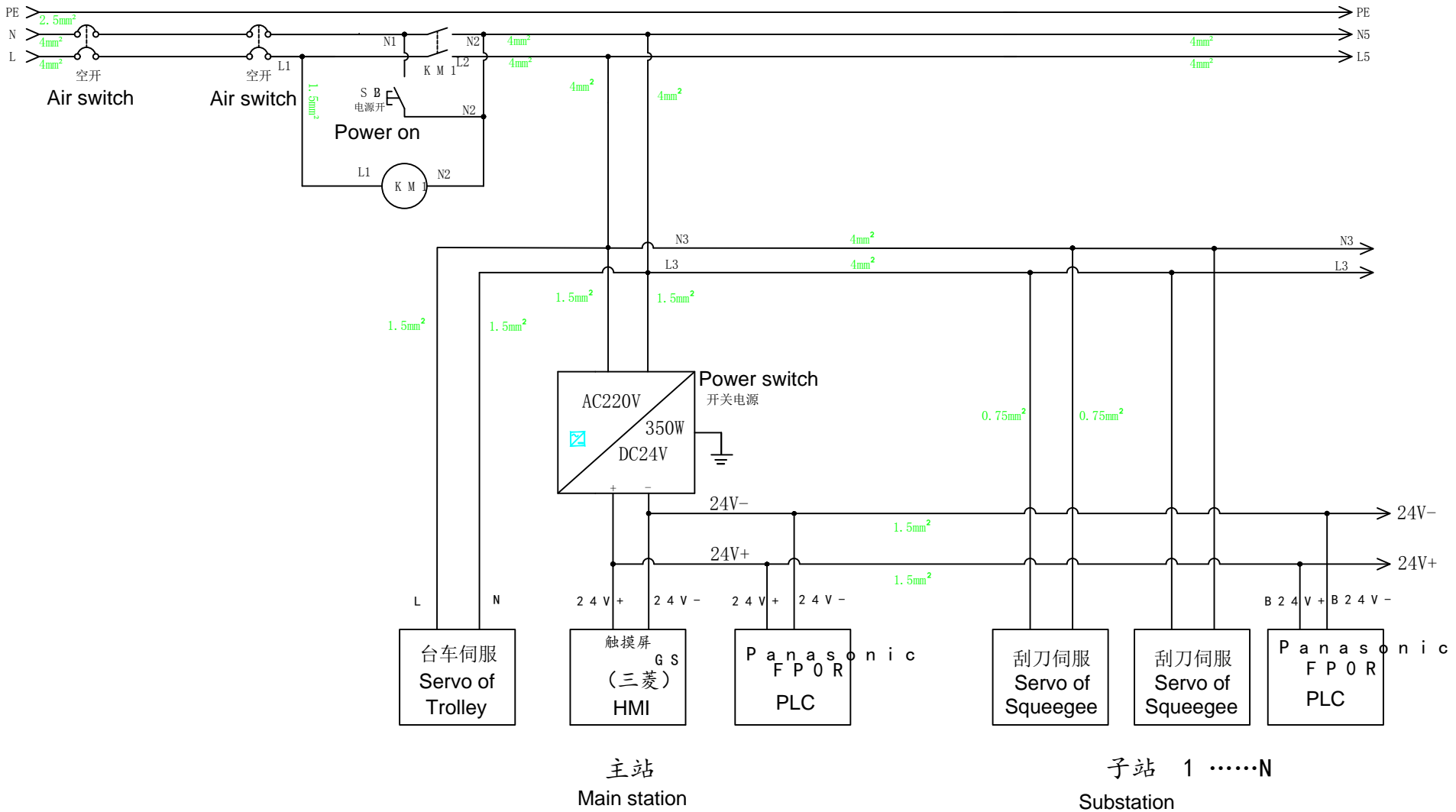

电气图纸名:	主从电箱	版本	X0.1
图号:	ST-RX-JL-01	数量	比例
制作:	广州市碧宏印刷科技有限公司		
共 9 页	第 2 页	Guangzhou bihong	

# Wiring of Delta Servo A1 台达伺服A1接线图

## Parameters 参数调节:

P2-15: 0  
 P2-16: 0  
 P2-17: 0  
 P1-44: 12800 脉冲 Pulse  
 P1-01: 100 正反转

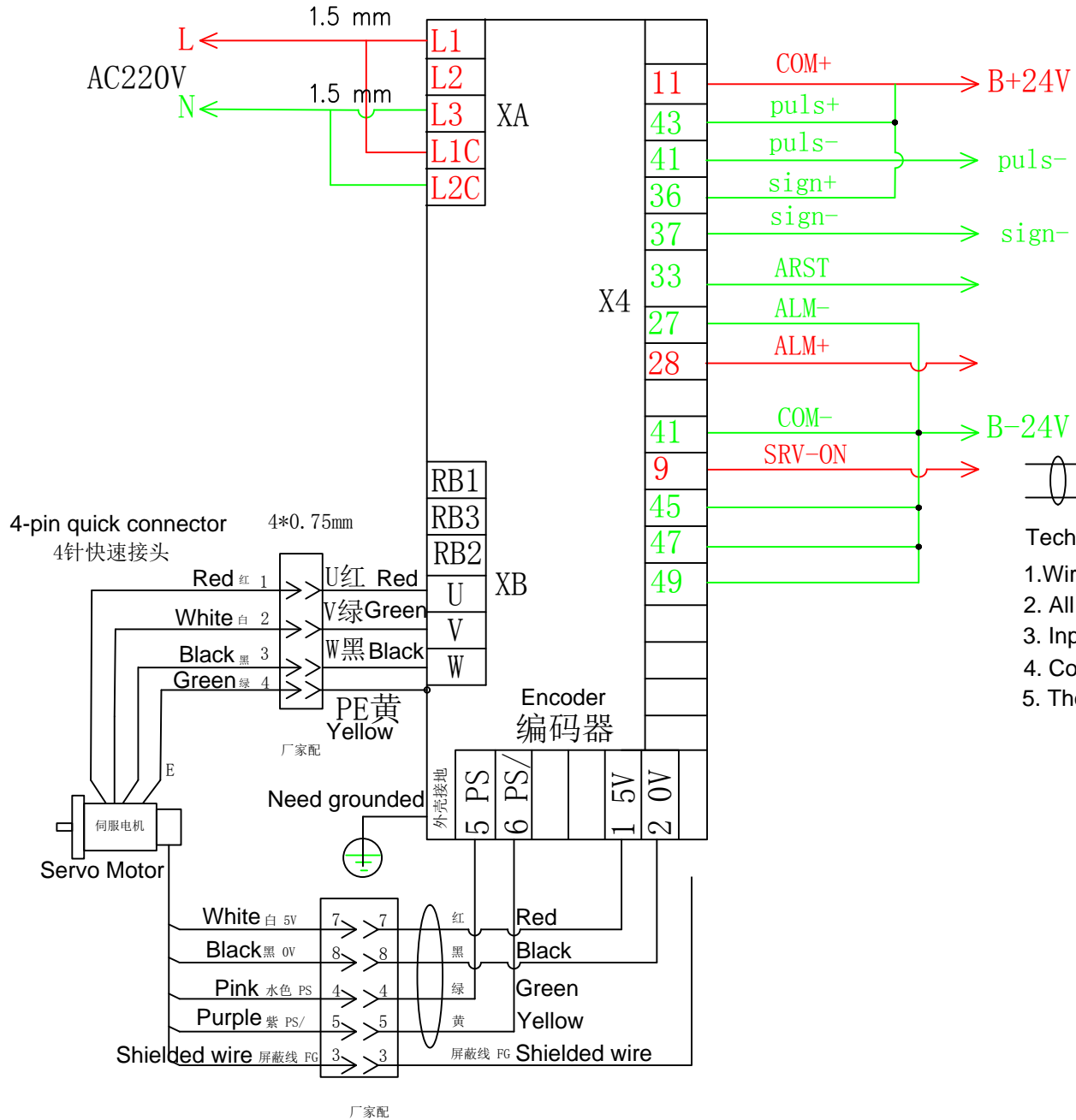

Technical requirement:

1. Wiring connection is right and firm.
2. All wiring has synthetic signal and signal is right and clear.
3. Input and output wires of PLC are distinguished with colors.
4. Control wires and power wires are put in different slots.
5. The case and other spare parts are connected with ground wire.



### 技术要求

1. 接线正确、牢固;
2. 所有线有同向线号, 线号正确清晰;
3. PLC输入输出线、动力线要以颜色区分;
4. 控制线和动力线必须分槽走, 走线美观大方;
5. 机箱和其他元器件按要求接好地线;

电气图纸名:	伺服接线图	版本	X0.1
图号:	ST-RX-JL-01	数量	比例
制作:	广州市碧宏印刷科技有限公司		
共 9 页	第 3 页	Guangzhou bihong	

# Wiring of Delta Servo B2 台达伺服B2接线图

## Parameters 参数调节:

P2-15: 0  
 P2-16: 0  
 P2-17: 0  
 P1-44: 1600 脉冲Pulse  
 P1-01: 100 正反转

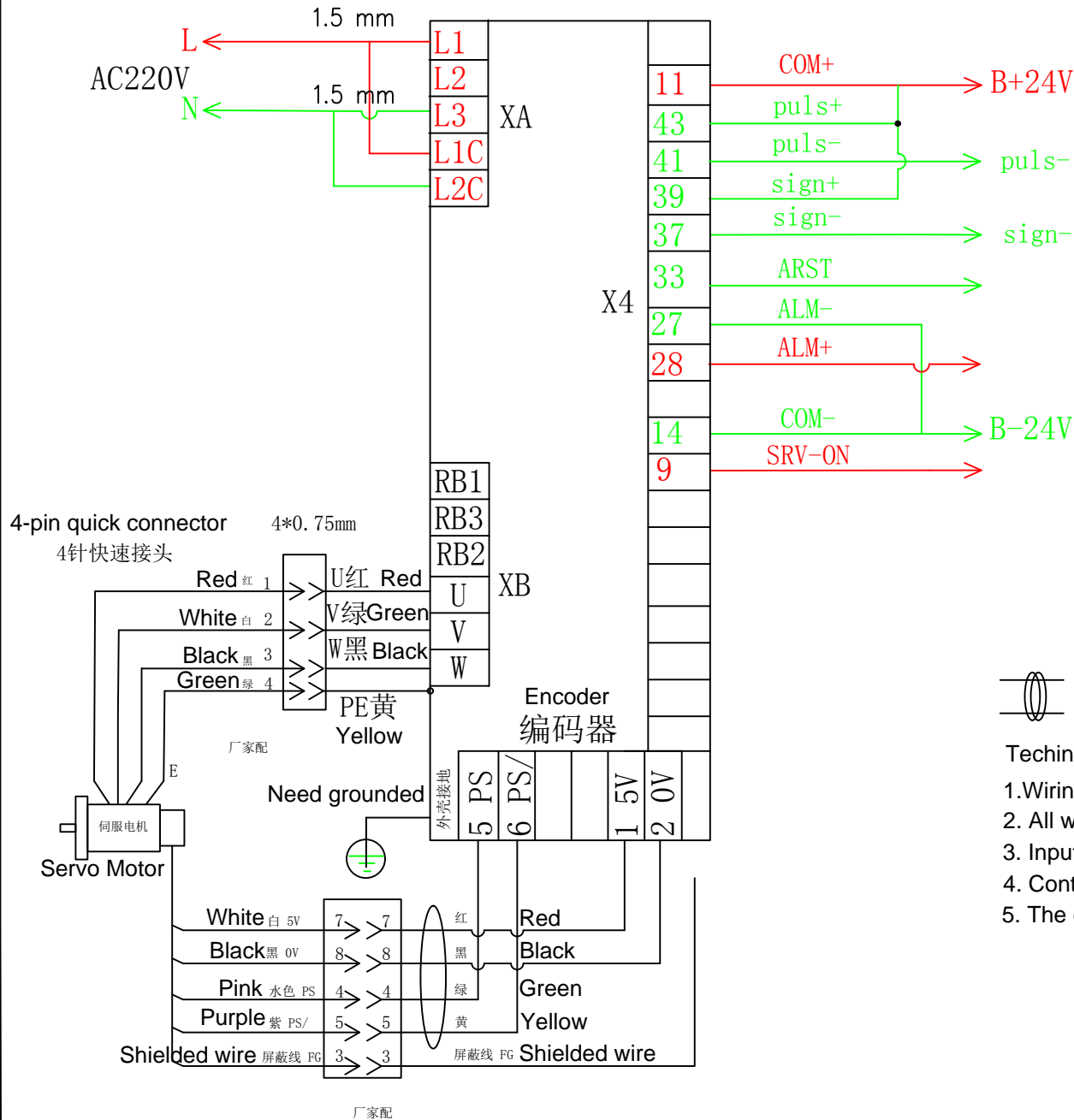

为双绞线

### 技术要求

1. 接线正确、牢固;
2. 所有线有同向线号, 线号正确清晰;
3. PLC输入输出线、动力线要以颜色区分;
4. 控制线和动力线必须分槽走, 走线美观大方;
5. 机箱和其他元器件按要求接好地线;

Twisted-pair

### Technical requirement:

1. Wiring connection is right and firm.
2. All wiring has synthetic signal and signal is right and clear.
3. Input and output wires of PLC are distinguished with colors.
4. Control wires and power wires are put in different slots.
5. The case and other spare parts are connected with ground wire.

电气图纸名:	伺服接线图	版本	X0.1
图号:	ST-RX-JL-01	数量	比例
制作:	广州市碧宏印刷科技有限公司		
共 9 页	第 4 页	Guangzhou bihong	

# HMI

## RS232

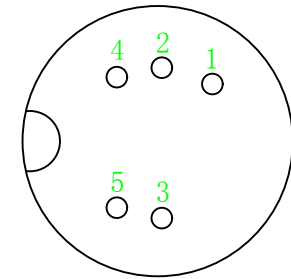
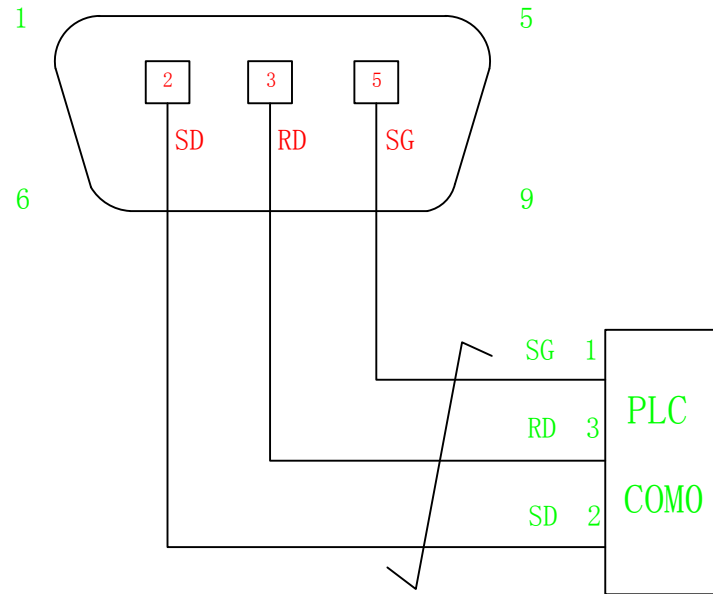
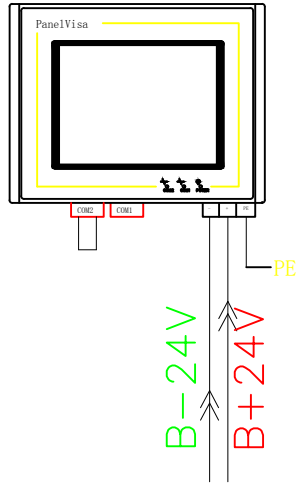

电气图纸名:	显示屏接线图	版本	X0.1
图号:	ST-RX-JL-01	数量	比例
制作:		广州市碧宏印刷科技有限公司	
共 9 页	第 5 页	guangzhou welltec Ltd.	

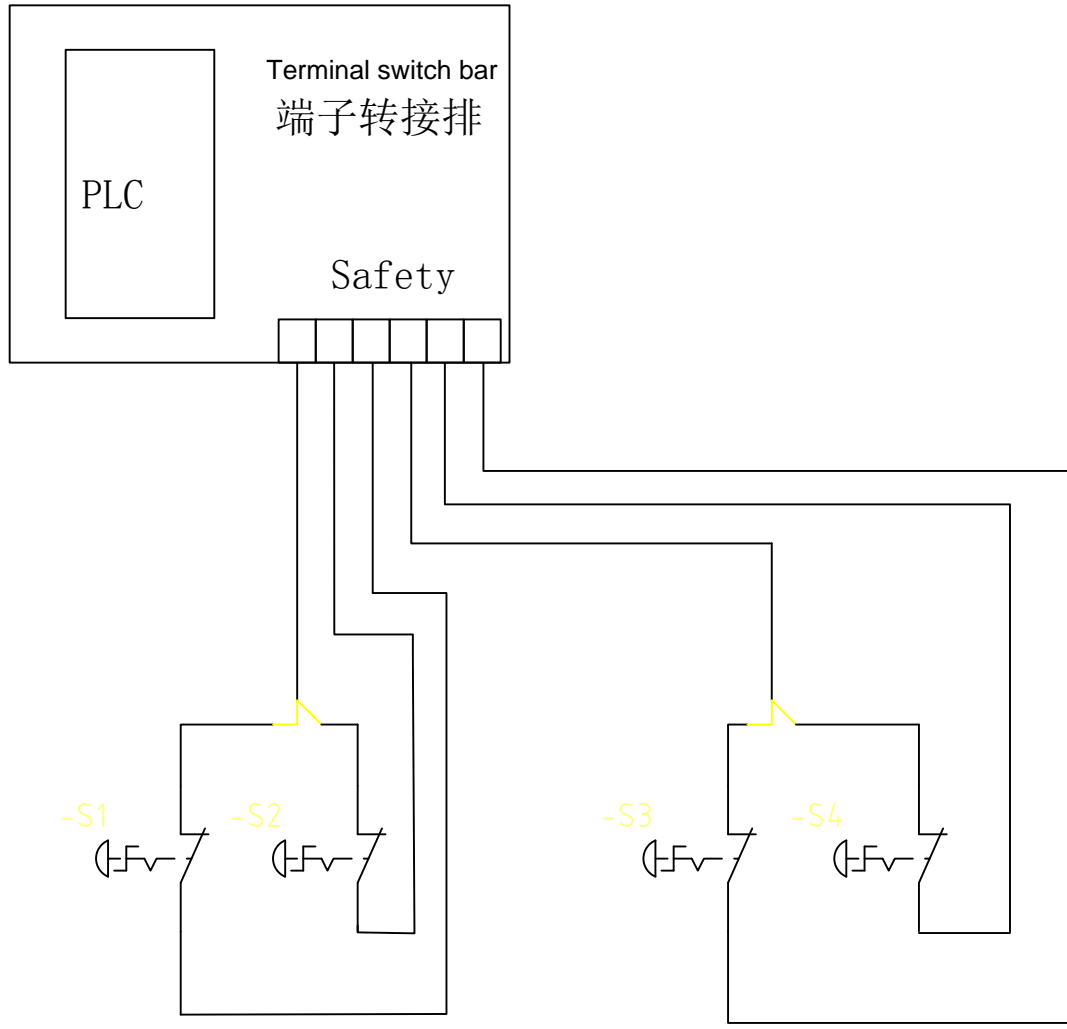

电气图纸名:		版本	X0.1
图号:	ST-RX-JL-01	数量	比例
制作:		广州市碧宏印刷科技有限公司	
共 9 页	第 6 页	guangzhou welltec Ltd.	

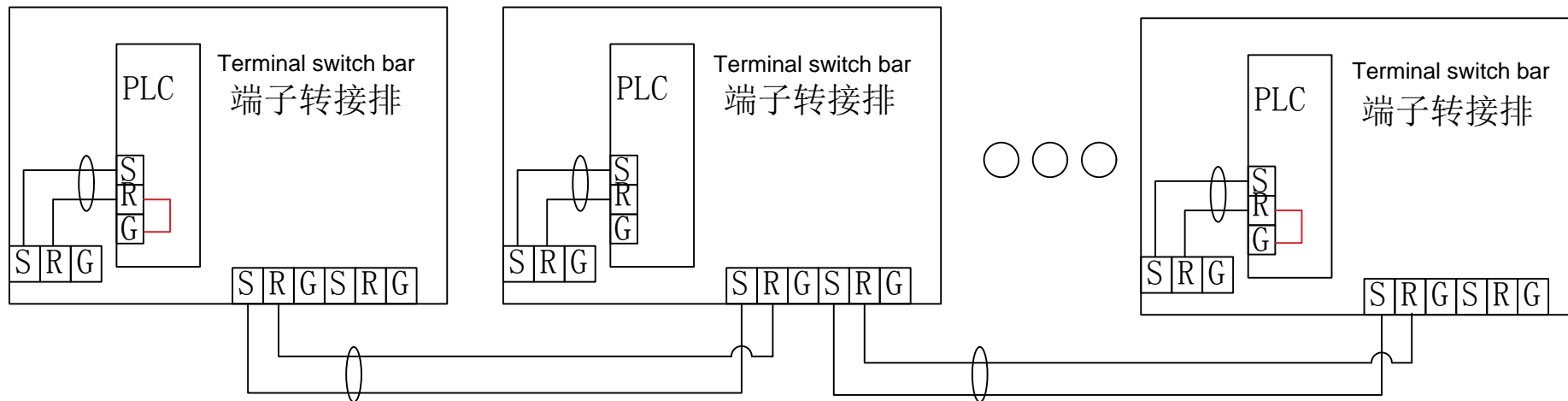

Wire connection between main station and substation

主站，子站连线

Twisted-pair  
为双绞线

电气图纸名:		版本	X0.1
图号:	ST-RX-JL-01	数量	比例
制作:		广州市碧宏印刷科技有限公司 guangzhou welltec Ltd.	
共 9 页	第 7 页		

X0 - a Servo alarm	X8 - a Outer sensor of squeegee	X20 - b Servo alarm	X28 - b Outer sensor of squeegee
X1 - a Power switch	X9 - a Inner sensor of squeegee	X21 - b Power switch	X29 - b Inner sensor of squeegee
X2 - a Pause button	XA - a Sensor under frame	X22 - b Pause button	X2A - b Sensor under frame
X3 - a Frame button	XB - a Positioning sensor	X23 - b Frame button	X2B - b Positioning sensor
X4 - a Forward button	XC - a SUB	X24 - b Forward button	X2C - b SUB
X5 - a Start button	XD - a Foot pededal switch	X25 - b Start button	X2D - b Foot pededal switch
X6 - a Backward button	XE - a ADD	X26 - b Backward button	X2E - b ADD
X7 - a Printing button	XF - a FUN	X27 - b Printing button	X2F - b FUN

图纸编号 ST

24v

0v

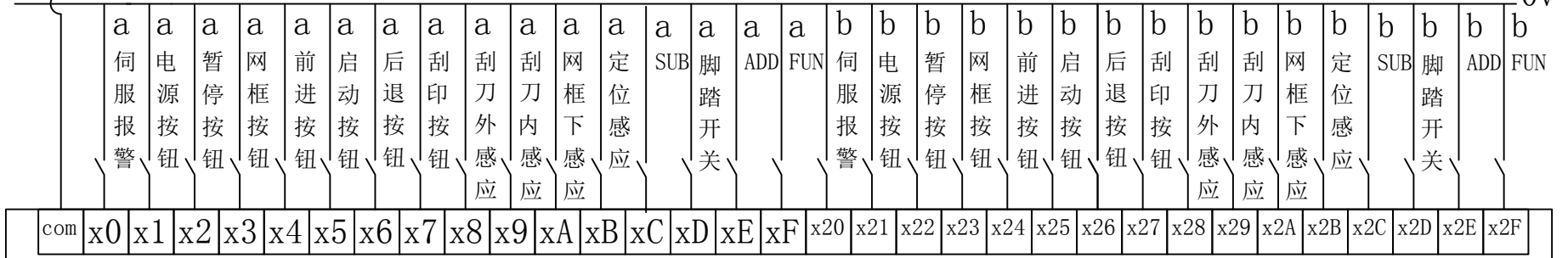

### Wiring of PLC of Substation

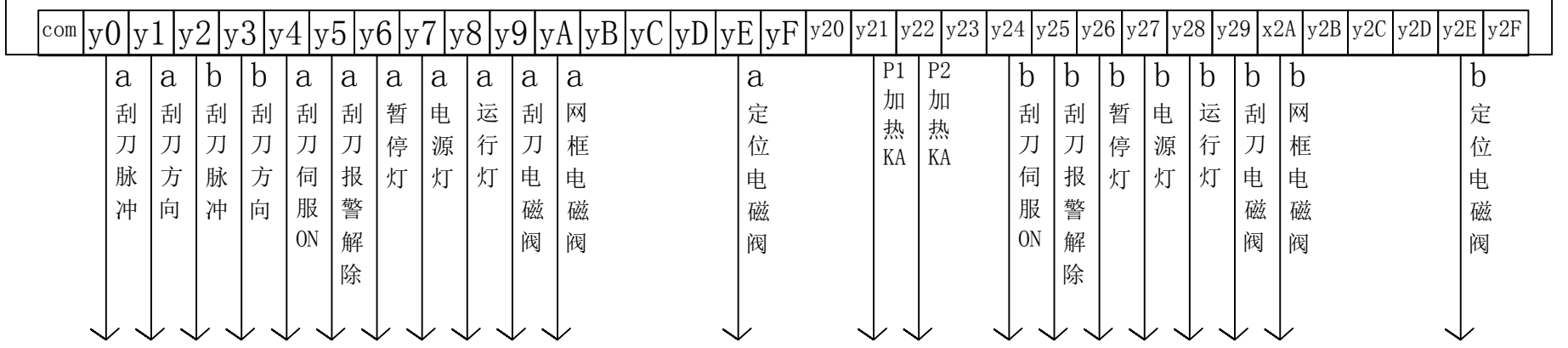

Y0 - a Pulse of squeegee	YE - a Solenoid valve of Positioning
Y1 - a direction of squeegee	Y21 - P1 Flash cure KA
Y2 - b Pulse of squeegee	Y22 - P2 Flash cure KA
Y3 - b direction of squeegee	Y24 - b Servo of squeegee ON
Y4 - a Servo of squeegee ON	Y25 - b Alarm cancel of squeegee
Y5 - a Alarm cancel of squeegee	Y26 - b Pause light
Y6 - a Pause light	Y27 - b Power light
Y7 - a Power light	Y28 - b Working light
Y8 - a Working light	Y29 - b Solenoid valve of squeegee
Y9 - a Solenoid valve of squeegee	X2A - b Solenoid valve of frame
YA - a Solenoid valve of frame	Y2E - b Solenoid valve of Positioning

电气图纸名:	从站PLC	版本	X0.1
图号:	ST-RX-JL-01	数量	比例
制作:	广州市碧宏印刷科技有限公司		
共 9 页	第 8 页	guangzhou welltec Ltd.	



- |   |   |  |
|---|---|--|
| X0 - Origin sensor                        | XC - Manual button of heat press 2        | X24 - Inner positioning sensor of flocking 1 |
| X1 - Servo alarm                          | XD - Up cylinder sensor of heat press 2   | X25 - Power switch of flocking 2             |
| X2 - Emergency stop                       | XE - Down cylinder sensor of heat press 2 | X26 - Manual button of flocking 2            |
| X4 - Emergency stop                       | XF - Switch signal of heat press 2        | X27 - Inner up sensor of flocking 2          |
| X8 - Manual button of heat press 1        | X20 - Power switch of flocking 1          | X28 - Outer up sensor of flocking 2          |
| X9 - Up cylinder sensor of heat press 1   | X21 - Manual button of flocking 1         | X29 - Inner positioning sensor of flocking 1 |
| XA - Down cylinder sensor of heat press 1 | X22 - Inner up sensor of flocking 1       | X2A - Digital printing                       |
| XB - Switch signal of heat press 1        | X23 - Outer up sensor of flocking 1       | X2F - Digital positioning sensor             |

图纸编号

ST

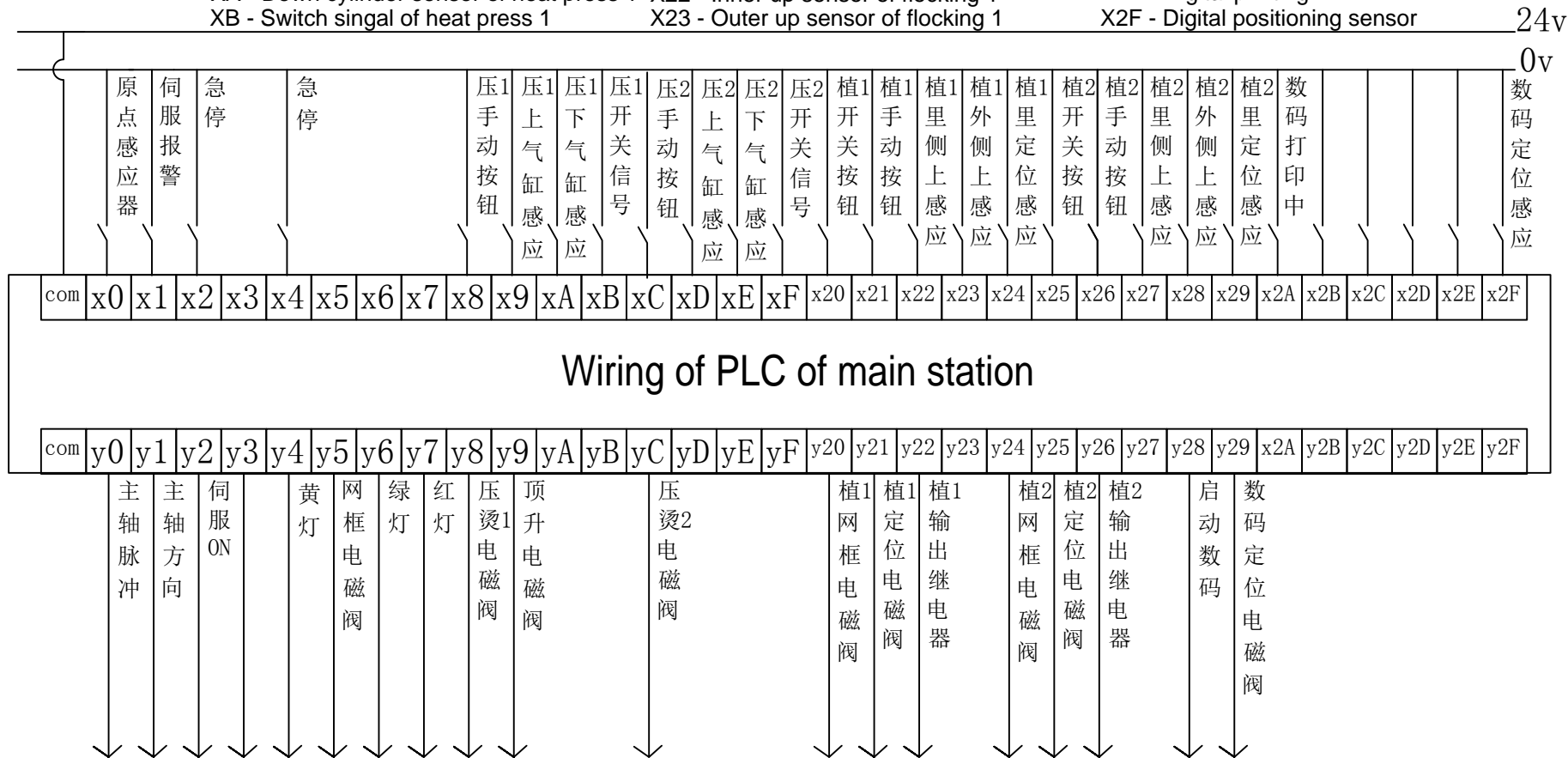

- Y0 - Pulse of main axis
- Y1 - Direction of main axis
- Y2 - Servo ON
- Y4 - Yellow light
- Y5 - Frame valve
- Y6 - Green light
- Y7 - Red light
- Y8 - Up valve of heat press 1
- Y9 - Down valve of heat press 1

- YC - Solenoid valve of heat press 2
- Y20 - Frame valve of flocking 1
- Y21 - Positioning valve of flocking 1
- Y22 - Output relay of flocking 1
- Y24 - Frame valve of flocking 2
- Y25 - Positioning valve of flocking 2
- Y26 - Output relay of flocking 2
- Y28 - Start digital
- Y28 - Digital positioning valve

电气图纸名:	主站PLC	版本	X0.1
图号:	ST-RX-JL-01	数量	比例
制作:	广州市碧宏印刷科技有限公司		
共 9 页	第 9 页	guangzhou welltec Ltd.	